

Ceiling swirl diffusers with perforated face plate

Type DCS

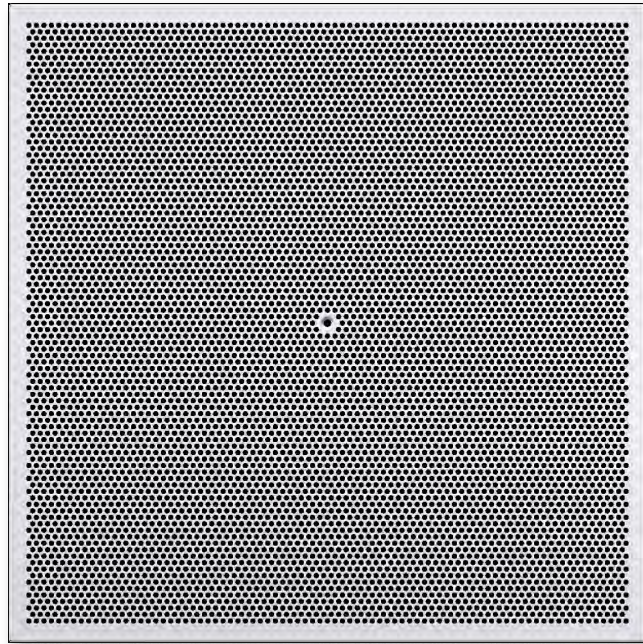

For horizontal swirling supply air discharge creating high induction levels, with fixed air control blades

Square ceiling swirl diffusers with perforated face plate, for comfort and industrial zones

- Nominal diffuser face size 600
- Volume flow rate range 4 – 260 l/s or 16 – 936 m³/h
- Perforated diffuser face made of galvanised sheet steel, powder-coated with plain perimeter border and central screw fixing
- For supply and extract air
- For variable and constant volume flows
- For all types of ceiling systems, particularly for T-bar ceilings
- Swirl unit inside, 6 sizes, for the best swirl effect and high induction levels
- Ideal for comfort zones

Optional equipment and accessories

- Exposed diffuser face available in RAL CLASSIC colours
- Horizontal or vertical duct connection
- Plenum box with lining

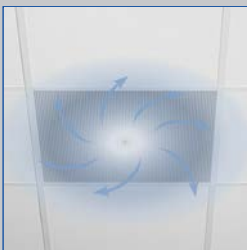

Horizontal swirling air discharge

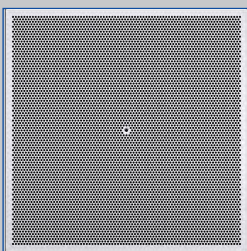

Perforated diffuser face

Type		Page
DCS	General information	DCS – 2
	Function	DCS – 3
	Technical data	DCS – 4
	Specification text	DCS – 6
	Order code	DCS – 7
	Variants	DCS – 10
	Dimensions and weight	DCS – 11
	Installation variants	DCS – 13
	Installation details	DCS – 14
	Basic information and nomenclature	DCS – 16

Application

Application

- Type DCS ceiling swirl diffusers are preferably used as supply air diffusers for comfort and industrial zones
- Perfect integration with suspended perforated sheet metal ceilings
- Horizontal swirling supply air discharge for mixed flow ventilation
- The efficient swirl creates high induction levels, thereby rapidly reducing the temperature difference and airflow velocity (supply air variant)
- For variable and constant volume flows
- For supply air to room air temperature differences –12 to +10 K

- For room heights up to 4 m (lower edge of suspended ceiling)
- For all types of ceiling systems

Special characteristics

- Horizontal air discharge creating high induction levels
- Design variants with perforated square diffuser face style
- For all types of ceiling systems
- Horizontal or vertical duct connection

Nominal sizes

- Diffuser face: 600
- Swirl diffuser: 125, 160, 200, 250, 315, 400

Description

Variants

- DCS-P: Perforated diffuser face

Installation type

- Q: Face mounted
- QL: Lay-in flat 'T' bar
- QS15: Tegular 'T' bar 15x8
- QS26: Tegular 'T' bar 26x8
- QM15: Tegular 'T' bar 15x16
- QM26: Tegular 'T' bar 26x16
- QB: Push-in spring 'T' (Burgess)

Connection

- K: Vertical duct connection, with duct collar
- AK: Diffuser suitable for horizontal plenum
- RA: Diffuser suitable for return air baffle

Accessories

- Plenum box with horizontal connection
- Return air baffle

Parts and characteristics

- Square diffuser face - Nominal 46% F.A
- 7 standard border profiles to suit most ceilings
- Swirl unit with radially arranged fixed air control blades

Construction features

- Spigot suitable for circular ducts to EN 1506 or EN 13180

Materials and surfaces

- Diffuser face, discharge nozzle, swirl unit, duct collar and plenum box made of galvanised sheet steel
- Plenum box lining is Class 'O' acoustic foam
- Swirl unit and discharge nozzle powder-coated RAL 9005, jet black
- P3: Perforated face powder-coated RAL 9010:20%
- P6: Perforated face powder-coated, RAL CLASSIC colour, 30% gloss

Standards and guidelines

- Sound power level of the air-regenerated noise measured according to EN ISO 5135

Maintenance

- Maintenance-free as construction and materials are not subject to wear
- Inspection and cleaning to VDI 6022

Functional description

Ceiling swirl diffusers in air conditioning systems create a swirl to supply air to rooms. The resulting airflow induces high levels of room air, thereby rapidly reducing the airflow velocity and the temperature difference between supply air and room air. Ceiling swirl diffusers allow for large volume flow rates. The result is a mixed flow ventilation in comfort zones, with good overall room ventilation, creating only very little turbulence in the occupied zone.

Type DCS ceiling swirl diffusers have fixed blades. The swirl unit required for the swirling air discharge is situated inside the plenum box, concealed by a perforated plate, and hence not visible from the room. Air discharge is horizontal omni directional. The supply air to room air temperature difference may range from -12 to $+10$ K.

To give rooms an aesthetic, uniform look, Type DCS diffusers may also be used for extract air.

Schematic illustration of the DCS, with perforated diffuser face and plenum box for horizontal duct connection

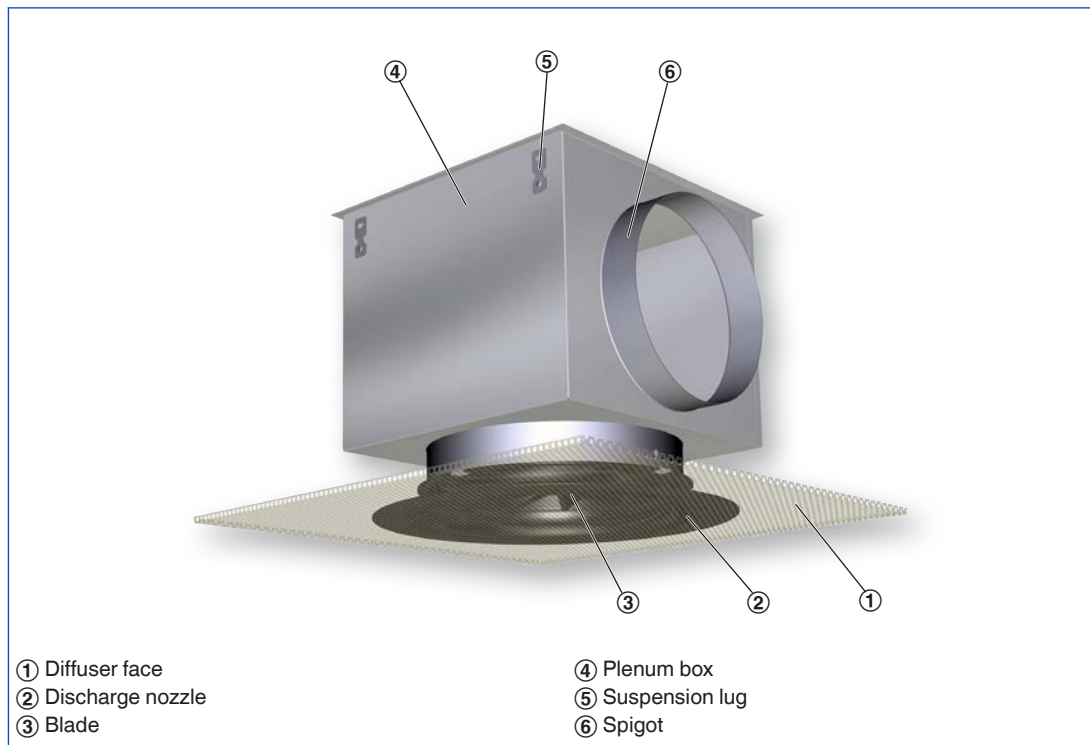

Horizontal omni-directional air discharge

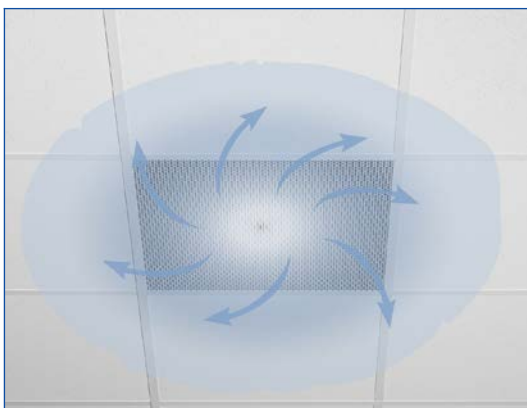

Nominal size – diffuser face	600 mm
Nominal sizes – swirl unit	125, 160, 200, 250, 315, 400 mm
Minimum volume flow rate, with $\Delta t_z = -6$ K	4 – 36 l/s or 16 – 128 m ³ /h
Maximum volume flow rate, with $L_{WA} \cong 50$ dB(A)	37 – 260 l/s or 132 – 936 m ³ /h
Supply air to room air temperature difference	-12 to +10 K

Quick sizing tables provide a good overview of the volume flow rates and corresponding sound power levels and differential pressures.

The minimum volume flow rates apply to a supply air to room air temperature difference of -6 K.

The maximum volume flow rates apply to a sound power level of approx. 50 dB (A) with damper blade position 0°.

Exact values for all parameters can be determined with our Easy Product Finder design programme.

DCS-P-*K, sound power level and total differential pressure

Nominal size	\dot{V}		Δp_t Pa	L_{WA} dB(A)
	l/s	m ³ /h		
125	15	54	10	20
	19	68	15	27
	22	79	20	31
	24	86	25	33
160	24	86	10	21
	29	104	15	26
	34	122	20	29
	38	137	25	32
200	38	137	10	22
	47	169	15	28
	54	194	20	32
	61	220	25	35
250	56	202	10	24
	68	245	15	30
	78	281	20	34
	87	313	25	37
315	90	324	10	28
	108	389	15	32
	124	446	20	36
	140	504	25	38
400	116	418	10	25
	140	504	15	31
	160	576	20	35
	180	648	25	39

DCS-P-...-AK + AKV-...-ZH supply plenum, sound power level and total differential pressure

Nominal size	\dot{V}		Δp_t	L_{WA}
	l/s	m ³ /h	Pa	dB(A)
125	13	47	10	<15
	16	58	15	21
	19	68	20	35
	21	76	25	51
160	22	79	10	<15
	27	97	15	20
	32	115	20	36
	36	130	25	50
200	33	119	10	<15
	40	144	15	22
	46	166	20	39
	52	187	25	50
250	50	180	10	<15
	60	216	15	23
	70	252	20	38
	78	281	25	50
315	76	274	10	<15
	90	324	15	25
	106	382	20	38
	118	425	25	50
400	106	382	10	<15
	128	461	15	25
	150	540	20	39
	166	598	25	50

DCS-P-...-RA + AKV-...-RA return air plenum, sound power level and total differential pressure

Nominal size	\dot{V}		Δp_t	L_{WA}
	l/s	m ³ /h	Pa	dB(A)
600	138	497	10	<15
	166	598	15	<15
	198	713	20	<15
	220	792	25	<15

This specification text describes the general properties of the product. Texts for variants can be generated with our Easy Product Finder design programme.

Design ceiling swirl diffusers with perforated square diffuser face, for comfort zones with particularly demanding requirements of aesthetics and design. For supply air or extract air. Excellent aerodynamic and acoustic function due to fixed air control blades for horizontal swirling air discharge, creating high levels of induction. For installation into all types of suspended ceilings. Ready-to-install component which consists of the diffuser face, a top entry spigot or a plenum box with equalising element, a side entry spigot, and suspension lugs. Spigot suitable for ducts to EN 1506 or EN 13180. Sound power level of the air-regenerated noise measured according to EN ISO 5135.

Special characteristics

- Horizontal air discharge creating high induction levels
- Design variants with perforated square diffuser face style
- For all types of ceiling systems
- Horizontal or vertical duct connection

Materials and surfaces

- Diffuser face, discharge nozzle, swirl unit, duct collar and plenum box made of galvanised sheet steel
- Plenum box lining is Class 'O' acoustic foam
- Swirl unit and discharge nozzle powder-coated RAL 9005, jet black
- P3: Perforated face powder-coated RAL 9010:20%
- P6: Perforated face powder-coated, RAL CLASSIC colour, 30% gloss

Technical data

- Nominal size – diffuser face: 600 mm
- Nominal sizes – swirl unit: 125, 160, 200, 250, 315, 400 mm
- Minimum volume flow rate, with $\Delta_t = -6$ K: 4 – 36 l/s or 16 – 128 m³/h
- Maximum volume flow rate, with $L_{WA} \approx 50$ dB(A): 37 – 260 l/s or 132 – 936 m³/h
- Supply air to room air temperature difference: -12 to +10 K

Sizing data

- \dot{V} _____
[m³/h]
- Δp_t _____
[Pa]
- Air-regenerated noise
- L_{WA} _____
[dB(A)]

Diffuser

DCS

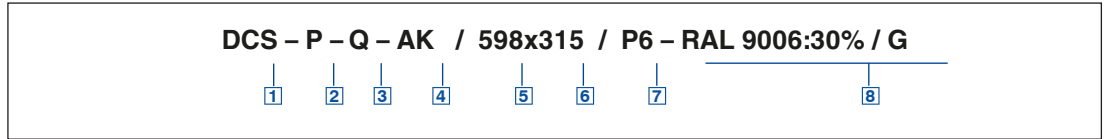

1 Type

DCS Swirl diffuser

2 Construction style

P Diffuser face, perforated

3 Installation type

- Q** Face mounted
- QL** Lay-in flat 'T' bar
- QS15** Tegular 'T' bar 15x8
- QS26** Tegular 'T' bar 26x8
- QM15** Tegular 'T' bar 15x16
- QM26** Tegular 'T' bar 26x16
- QB** Push in, spring 'T' bar

4 Connection

- K** Diffuser suitable for vertical connection with duct collar
- AK** Diffuser suitable for horizontal plenum
- RA** Diffuser face suitable for return air baffle

5 Diffuser face size [mm]

- Q** 598
- QL** 595
- QS15/QM15** 584
- QS26/QM26** 573
- QB** 599

6 Nominal diffuser size [mm]

- 125**
- 160**
- 200**
- 250**
- 315**
- 400**

7 Exposed surface

- P3** Perforated diffuser face powder-coated RAL9010:20%
- P6** Perforated diffuser face powder-coated RAL CLASSIC colour, 30% gloss

8 Screw cap colour

- W** White
- B** Black
- G** Grey

Order example: DCS–P–Q–AK/598x315/P6 - RAL9006:30% / G

Construction style	Perforated diffuser face
Installation type	Face mounted
Connection	Diffuser suitable for horizontal plenum (supply)
Diffuser face size	598x598
Nominal diffuser size	315 mm
Exposed surface	RAL 9006, silver grey, gloss level 30%Grey
Screw cap colour	

Plenum box

AKV-DCS

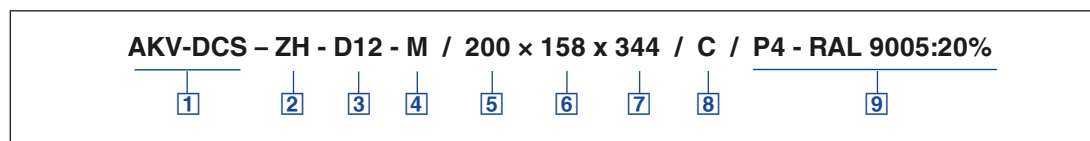

1 Plenum type

AKV-DCS

2 Construction

ZH Horizontal supply
AH Horizontal extract

3 Internal lining

0 No lining
D12 12mm Class 'O' internal foam lining

4 Damper

0 No damper
M Perforated spigot damper

5 Nominal diffuser size

125
160
200
250
315
400

6 Spigot Size [mm]

Ø98mm [DCS/125]
Ø123mm [DCS/160]
Ø158mm [DCS/200]
Ø198mm [DCS/250]
Ø248mm [DCS/315]
Ø313mm [DCS/400]

7 Assembled height [mm]

DCS/125, 160, 200, 250: ØD+186
DCS/315, 400: ØD+196

8 Exposed surface

0 Unpainted
C Powder-coated

9 Paint colour

0 Not required
P4 RAL 9005:20% (black)
P6 RAL CLASSIC colour, Gloss level 30%

Order example: AKV-DCS-ZH-D12-M / 200x158x344 / C / P4 - RAL9005:20%

Plenum type	Horizontal supply air
Internal lining	12mm foam
Damper	Perforated spigot damper
Nominal diffuser size	Ø200mm
Spigot size	Ø158mm
Assembled height	344mm
Exposed surface	Powder-coat finish
Colour finish	RAL9005:20% (black)

Return air baffle

AKV-DCS

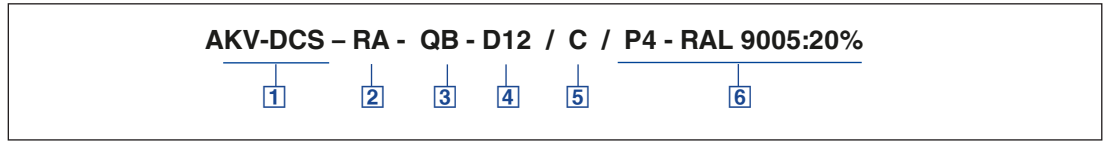

1 Plenum type

AKV-DCS

2 Construction

RA Return air baffle

3 Diffuser type

- Q** Face mounted
- QL** Lay-in flat 'T' bar
- QS15** Tegular 'T' bar 15x8
- QS26** Tegular 'T' bar 26x8
- QM15** Tegular 'T' bar 15x16
- QM26** Tegular 'T' bar 26x16
- QB** Push in, spring 'T' bar

4 Internal lining

- 0** No lining
- D12** 12mm Class 'O' internal foam lining

5 Exposed surface

- C** Powder-coated

6 Paint colour

- P4** RAL 9005:20% (black)
- P6** RAL CLASSIC colour, Gloss level 30%

Order example: AKV-DCS-RA-QB-D12 / C / P4 - RAL9005:20%

Plenum type	DCS
Construction style	Return air baffle
Diffuser type	QB (clip in)
Internal lining	12mm foam
Exposed surface	Powder-coat finish
Colour finish	RAL9005:20% (black)

DCS-P

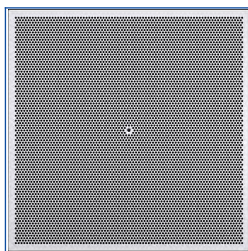

DCS-P-...-K

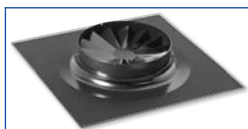

DCS-P-...-AK + AKV-...-ZH



DCS-P-...-RA + AKV...-RA



DCS-P-...-K

Variant

- Ceiling swirl diffuser with perforated square diffuser face
- Perforated diffuser face with plain perimeter border and central screw fixing

Nominal sizes

- Diffuser face: 600
- Swirl diffuser: 125, 160, 200, 250, 315, 400

Parts and characteristics

- Perforated square diffuser face
- Circular duct collar for connection to a vertical duct

Construction features

- Spigot suitable for circular ducts to EN 1506 or EN 13180

DCS-P-...-AK + AKV-...-ZH

Variant

- Ceiling swirl diffuser with perforated square diffuser face and plain perimeter border and central screw fixing
- With plenum box for horizontal duct connection

Nominal sizes

- Diffuser face: 600
- Swirl diffuser: 125, 160, 200, 250, 315, 400

Parts and characteristics

- Perforated square diffuser face
- Plenum box for horizontal duct connection
- Plenum box with lining, optional

Construction features

- Spigot suitable for circular ducts to EN 1506 or EN 13180

DCS-P-...-AKV-*RA

Variant

- Perforated square diffuser face to match Type DCS supply diffuser with plain perimeter border and central screw fixing
- With return air baffle for extract applications

Nominal sizes

- Diffuser face: 600
- Return air baffle: 600

Parts and characteristics

- Perforated square diffuser face
- Return air baffle for extract applications
- Return air baffle with lining, optional

DCS-P-...-K

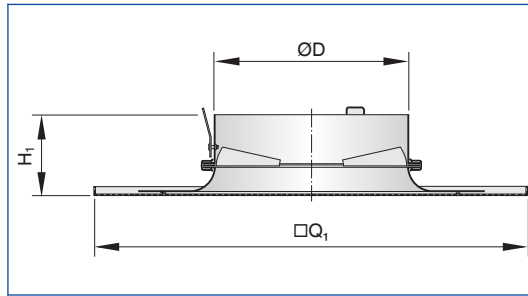

Nominal size	Q	QL	QS15 QM15	QS26 QM26	QB			
	□Q ₁					H ₁	ØD	m
	mm	mm	mm	mm	mm	mm	mm	kg
... x 125	598	595	584	573	599	77	123	2.2
... x 160	598	595	584	573	599	77	158	2.4
... x 200	598	595	584	573	599	77	198	2.5
... x 250	598	595	584	573	599	77	248	2.8
... x 315	598	595	584	573	599	87	313	3.4
... x 400	598	595	584	573	599	87	398	3.9

DCS-P-...-AK + AKV-...-ZH

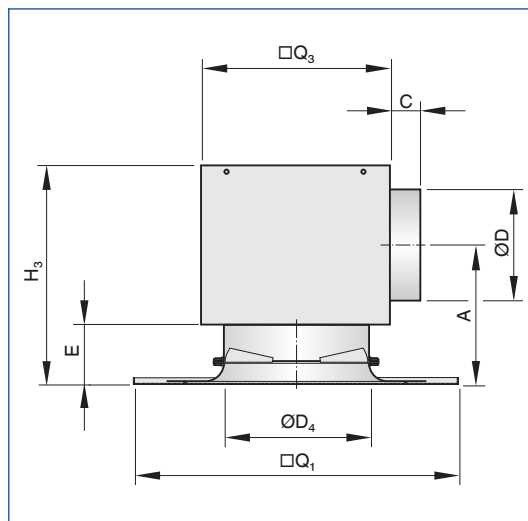

Nominal size	Q	QL	QS15 QM15	QS26 QM26	QB								
	□Q ₁					H ₃	□Q ₃	ØD ₄	E	ØD	A	C	m
	mm	mm	mm	mm	mm	mm	mm	mm	mm	mm	mm	mm	kg
... x 125	598	595	584	573	599	284	216	123	89	98	204	40/*75	4.3
... x 160	598	595	584	573	599	309	266	158	89	123	216	40/*75	5.4
... x 200	598	595	584	573	599	344	290	198	89	158	234	40/*75	6.0
... x 250	598	595	584	573	599	384	477	248	89	198	254	40/*75	10.1
... x 315	598	595	584	573	599	444	567	313	99	248	289	40/*75	13.3
... x 400	598	595	584	573	599	509	615	398	99	313	321	40/*75	15.9

* Increased dimension C when specified with ...-M or ...-MC spigot mounted damper

DCS-P-...-RA + AKV-...-RA

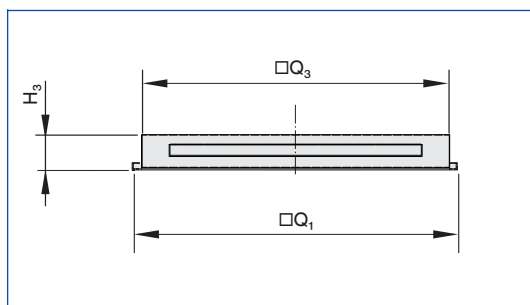

Nominal size	Q	QL	QS15 QM15	QS26 QM26			QB			
	Q_1				H_3	Q_3	Q_1	H_3	Q_3	m
	mm	mm	mm	mm	mm	mm	mm	mm	mm	kg
... x 600	598	595	584	573	85	565	599	112	550	5.2

DCS installation types

DCS-...-Q

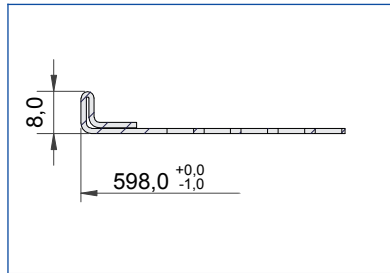

Face mounted

DCS-...-QL

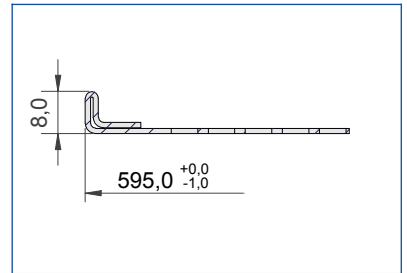

Lay-in flat 'T' bar

DCS-...-QS15

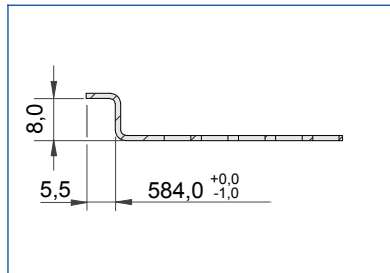

Tegular 'T' bar [15x8]

DCS-...-QM15

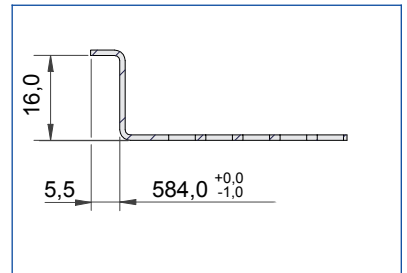

Tegular 'T' bar [15x16]

DCS-...-QS26

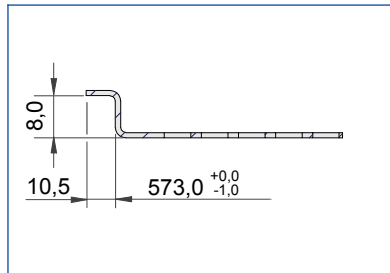

Tegular 'T' bar [26x8]

DCS-...-QM26

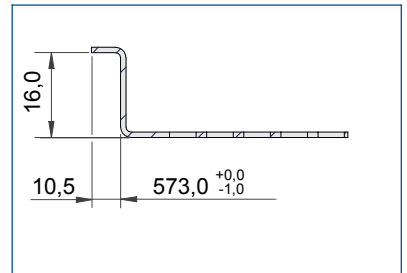

Tegular 'T' bar [26x16]

DCS-...-QB faceplate levelled via centre screw (i.e no location pip)

DCS-...-QB

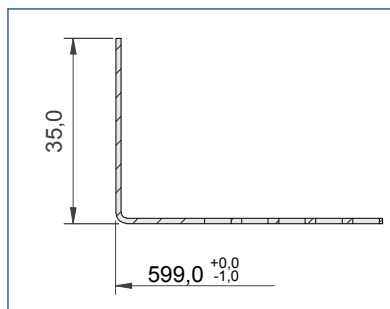

Push in, spring 'T' bar

Installation and commissioning

- Preferably for rooms with a clear height up to 4.0 m
- Flush ceiling installation
- Horizontal or vertical duct connection

Installation information

- Flush ceiling installation
- Installation and making connections to be performed by others

These are only schematic diagrams to illustrate installation details.

Installation with the T-bars exposed

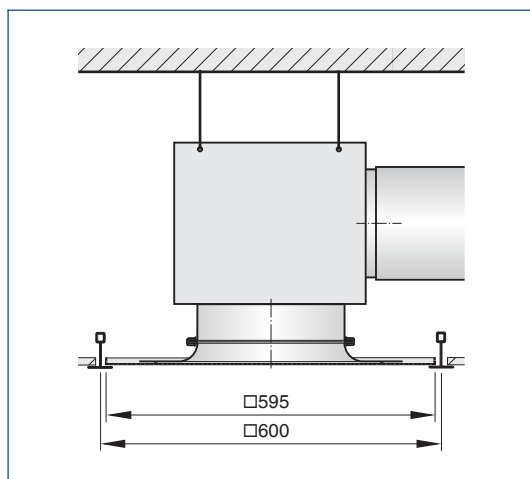

Variant DCS-...-AK-ZH

- Horizontal duct connection
- Four suspension lugs
- Diffuser face rests on T-bars (installation type ...-QL)

Installation with the T-bars exposed

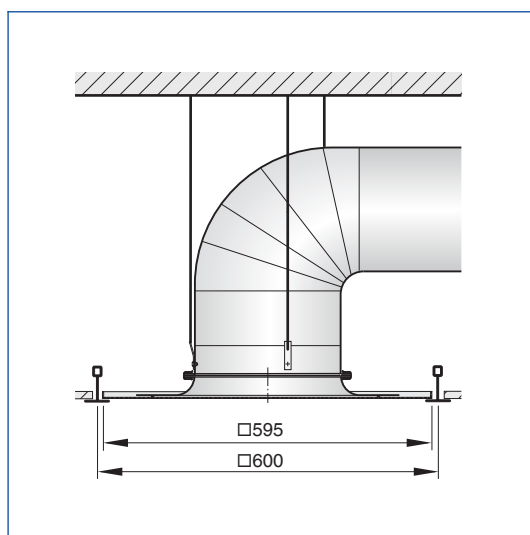

Variant DCS-...-K

- Vertical duct connection
- Three suspension lugs
- Diffuser face rests on T-bars (installation type ...-QL)

Installation information Type ...-AK

DCS-*-AK

- DCS diffuser face supplied assembled with temporary transportation fixing. Individual components fixed;
- Perforated fascia
- Blanking plate
- Spacer tube
- Swirl element

DCS-*-AK

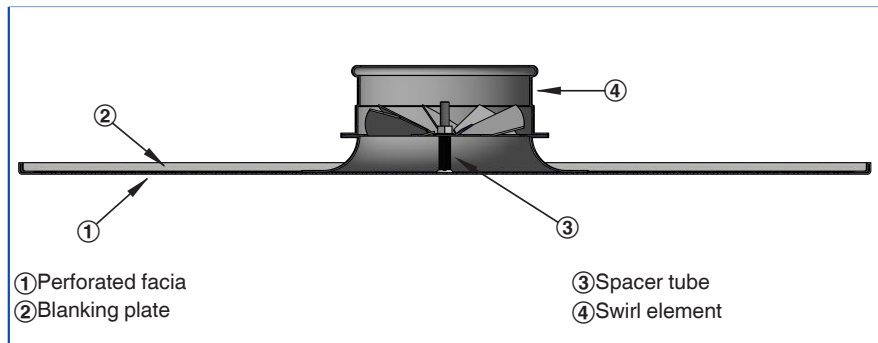

- To install Type DCS diffuser to TROX plenum box, remove the transportation fixing and install plenum fixing screw (long screw).
- Care should be taken to ensure all components are installed (blanking plate, spacer tube etc.)
- Plenum fixing screw should be inserted through all components and secured into plenum box cross bar
- Once secured into plenum, install plastic cover cap.

For installation with AK plenum

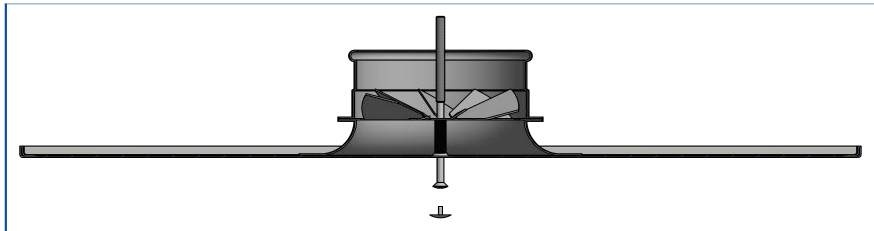

Principal dimensions

ØD [mm]

Outer diameter of the spigot

ØD₁ [mm]

Outer diameter of a circular diffuser face

ØD₂ [mm]

Diameter of a circular diffuser face style

ØD₃ [mm]

Diameter of a circular plenum box

□Q₁ [mm]

Outer diameter of a square diffuser face

□Q₂ [mm]

Dimensions of a square diffuser face style

□Q₃ [mm]

Dimensions of a square plenum box

H₁ [mm]

Distance (height) from the lower edge of the

suspended ceiling to the lower edge of the diffuser face

H₂ [mm]

Height of a ceiling diffuser, from the lower edge of the suspended ceiling to the upper edge of the spigot

H₃ [mm]

Height of a ceiling diffuser with plenum box, from the lower edge of the suspended ceiling to the upper edge of the plenum box or of the spigot

A [mm]

Position of the spigot, defined by the distance of the spigot centre line to the lower edge of the suspended ceiling

C [mm]

Length of the spigot

m [kg]

Weight

Nomenclature

L_{WA} [dB(A)]

A-weighted sound power level of air-regenerated noise

 \dot{V} [m³/h] and [l/s]

Volume flow rate

Δt₂ [K]

Supply air to room air temperature difference, i.e.

supply air temperature minus room temperature

Δp_t [Pa]

Total differential pressure

A_{eff} [m²]

Effective air discharge area

All sound power levels are based on 1 pW.