



**NON-RETURN DAMPER,  
VARIANT ARK**

Non-return damper with  
linkage

## ER – SELF-POWERED DAMPERS

### FOR THE FAST AND SIMPLE INSTALLATION OF NON-RETURN DAMPERS AND PRESSURE-RELIEF DAMPERS

Installation subframe for the fast and precise installation of non-return dampers and pressure-relief dampers. Installation subframes with fixing tabs are mortared into the wall opening, then the dampers are fastened to the subframes

- Angle sections made of galvanised steel or stainless steel
- Galvanised steel variant with screw-on fixing tabs
- Stainless steel variant with welded fixing tabs

## Application



### Application

- For the installation of non-return dampers and pressure-relief dampers in walls and ceiling slabs
- Simplified installation
- The installation subframe allows for the fast, simple and precise installation of non-return dampers and pressure-relief dampers

### Nominal sizes

- B: 200, 400, 600, 800, 1000, 1200 mm (intermediate sizes: 201 – 1199 mm, in increments of 1 mm)
- H: 345, 675, 1005, 1335, 1665, 1995 mm (intermediate sizes 355 – 505, 685 – 835, 1015 – 1165, 1345 – 1495, 1675 – 1825 mm in increments of 1 mm)
- Any combination of B × H

## Description



### Parts and characteristics

- Installation subframe consisting of angle sections
- Threaded studs or hexagon head screws
- Washers
- Hexagon nuts
- Fixing tab

## Materials and surfaces

### UL-1, UL-2

- Installation subframe made of galvanised steel (angle section 35 × 35 × 3 mm)
- Welded fixing tabs with integral nuts, screws and washers made of galvanised steel

### KUL, ARK, ARK2

- Installation subframe made of galvanised steel (angle section 35 × 35 × 3 mm)
- Screw-on fixing tabs, threaded studs, screws, nuts and washers made of galvanised steel

### ARK-A2, ARK2-A2

- Installation subframe made of stainless steel, material no. 1.4301
- Welded fixing tabs, threaded studs, nuts and washers made of stainless steel, material no. 1.4301

## TECHNICAL INFORMATION

### Function

---



Installation subframe made of galvanised steel for non-return dampers and pressure-relief dampers

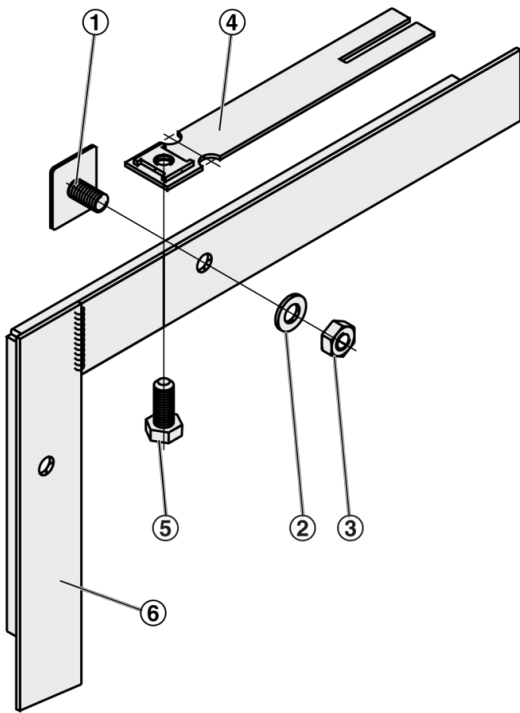

- ① Threaded stud
- ② Washer
- ③ Hexagon nut
- ④ Fixing tab
- ⑤ Hexagon head screw
- ⑥ Installation subframe

**Installation subframe for non-return dampers and pressure-relief dampers**

Description	Type
Galvanised steel	UL, KUL, ARK, ARK2
Stainless steel	ARK-A2, ARK2-A2

**Materials**

Part	Damper type or variant	Material	Notes
Installation subframe	UL, KUL, ARK, ARK2	Galvanised steel	Angle section frame 35 x 35 x 3 mm
	ARK-A2, ARK2-A2	Stainless steel, material no. 1.4301	
Fixing tabs, screws, nuts and washers	UL	Galvanised steel	Welded fixing tabs
	KUL, ARK, ARK2	Galvanised steel	Screw-on fixing tabs
Fixing tabs, threaded stubs, nuts and washers	ARK-A2, ARK2-A2	Stainless steel, material no. 1.4301	Welded fixing tabs

**Installation subframe ready to be mortared in**

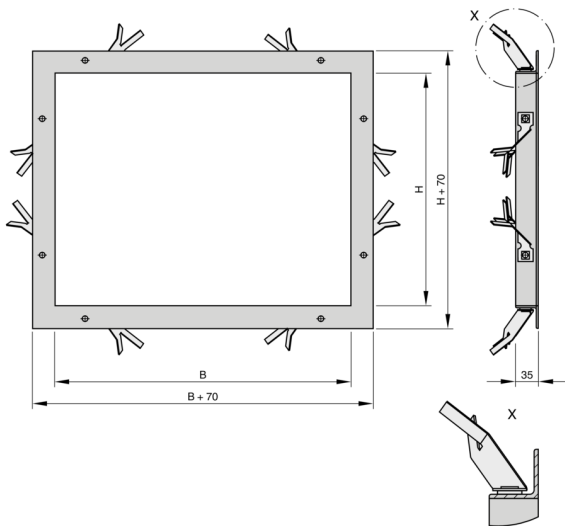

Before the subframe is mortared in, the fixing tabs must be bent and spread (by others).

## Installation and commissioning

UL

Before mortaring in the installation subframe

- Bend and spread the fixing tabs

After mortaring in the installation subframe

- Align the non-return damper with the subframe and fasten it

KUL, ARK, ARK2

Before mortaring in the installation subframe

- Fasten the threaded studs, washers and nuts to the installation subframe
- Fix the screw-on fixing tabs with hexagon nuts
- Fasten the remaining screw-on fixing tabs (regular spacing, about every 375 - 625 mm)

After mortaring in the installation subframe

- Unscrew the hexagon nuts
- Align the non-return damper or pressure-relief damper with the subframe and fasten it

## Installation in front of internal wall openings

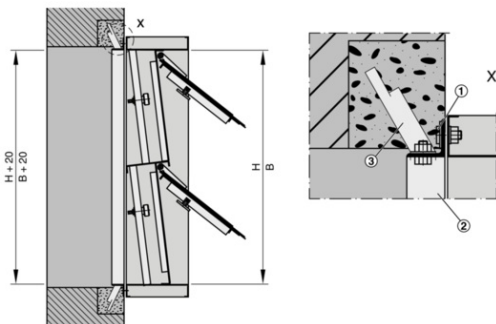

- ① Threaded stud
- ② Installation subframe
- ③ Fixing tab

Illustration shows ARK2