



INSTALLATION SUBFRAME

MULTILEAF DAMPER VARIANT JZ-P

Multileaf damper with
installation subframe and
actuator

ER – MULTILEAF DAMPERS

FOR THE FAST AND SIMPLE INSTALLATION OF MULTILEAF DAMPERS

Installation subframe for the fast and simple installation of multileaf dampers. Installation subframes with fixing tabs are mortared into the wall opening, then the multileaf dampers are fastened to the subframes.

- Angle sections made of galvanised steel or stainless steel
- Galvanised steel variant with screw-on fixing tabs
- Stainless steel variant with welded fixing tabs

Optional equipment and accessories

- Subdivided construction (width or height subdivided) for the installation of subdivided multileaf dampers (made of galvanised sheet steel) without support structure

Application



Application

- For the installation of multileaf dampers in walls and ceiling slabs
- Simplified installation
- The installation subframe allows for the fast, simple and precise installation of multileaf dampers

Description



Parts and characteristics

- Installation subframe made of angle sections or standard flanges
- Threaded studs
- Washers
- Hexagon nuts

- Fixing tabs

Materials and surfaces

JZ-S, JZ-P, JZ-LL, JZ-HL

- Installation subframe made of galvanised steel (angle section 35 × 35 × 3 mm)
- Screw-on fixing tabs, threaded studs, screws, nuts and washers made of galvanised steel

JZ-S-A2, JZ-P-A2, JZ-LL-A2

- Installation subframe made of stainless steel, material no. 1.4301 (angle section 35 × 35 × 3 mm)
- Welded fixing tabs, threaded studs, nuts and washers made of stainless steel, material no. 1.4301

JZ-AL, JZ-LL-AL, JZ-HL-AL

- Installation subframe made of galvanised steel (standard flange)
- Screw-on fixing tabs, threaded studs, screws, nuts and washers made of galvanised steel

TECHNICAL INFORMATION

Variants, Dimensions



Installation subframe for multileaf dampers

Description	Multileaf damper, Type
Galvanised steel	JZ-S, JZ-P, JZ-LL, JZ-HL
	JZ-AL, JZ-LL-AL, JZ-HL-AL
Galvanised steel, width subdivided	JZ-S, JZ-P, JZ-LL, JZ-HL
Galvanised steel, height subdivided	JZ-S, JZ-P, JZ-LL, JZ-HL
Stainless steel	JZ-S-A2, JZ-P-A2, JZ-LL-A2

Installation subframe for multileaf dampers and for smoke protection dampers

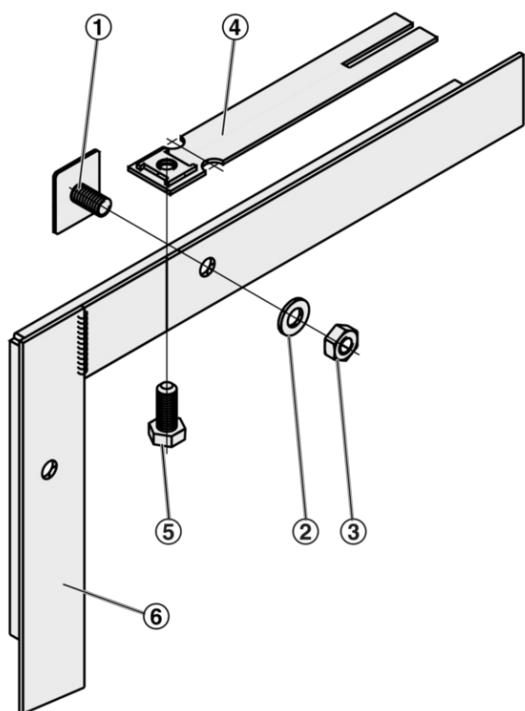

- ① Threaded stud
- ② Washer
- ③ Hexagon nut
- ④ Fixing tab
- ⑤ Hexagon head screw
- ⑥ Installation subframe

Installation subframe ready to be mortared in

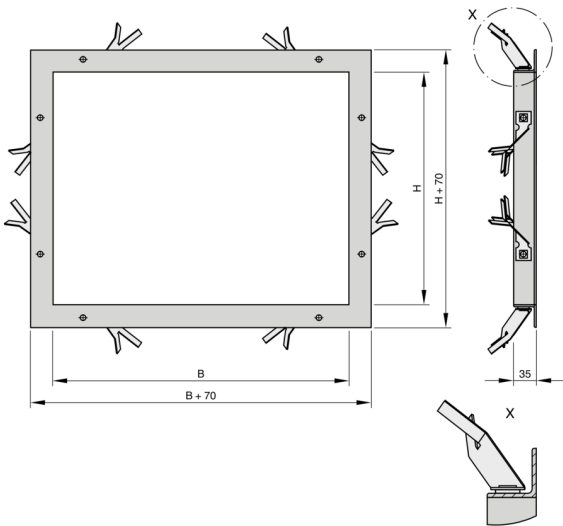

Before the subframe is mortared in, the fixing tabs must be bent and spread (by others).

Installation details



Installation and commissioning

Before mortaring in the installation subframe

- Fasten the threaded studs, washers and nuts to the installation subframe
- Fix the screw-on fixing tabs with hexagon nuts
- Fasten the remaining screw-on fixing tabs (regular spacing, about every 375 - 625 mm)

After mortaring in the installation subframe

- Unscrew the hexagon nuts
- Align the multileaf damper with the installation subframe and fasten it

Installation subframe for variants JZ-*, JZ-*-A2, JZ-LL, JZ-HL

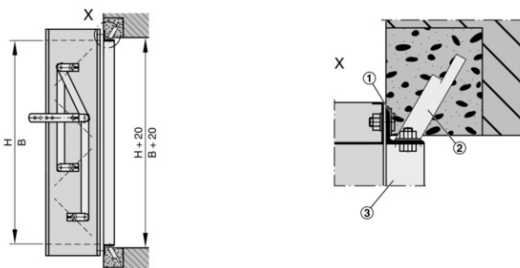

① Threaded stud

- ② Fixing tab
- ③ Installation subframe

Installation subframe for variants JZ-AL, JZ-*L-AL

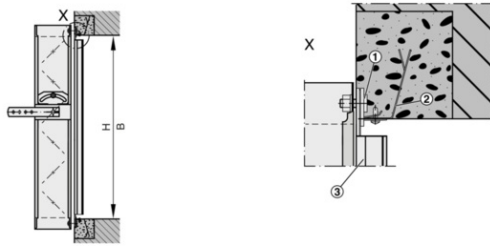

- ① Threaded stud
- ② Fixing tab
- ③ Installation subframe

Installation subframe, width subdivided

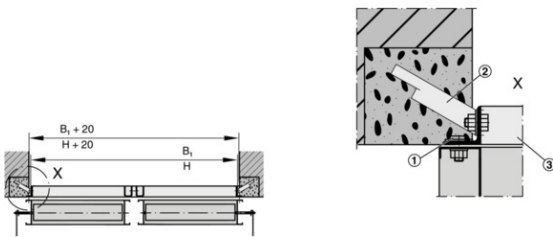

- ① Threaded stud
- ② Fixing tab
- ③ Installation subframe

Installation subframe, height subdivided

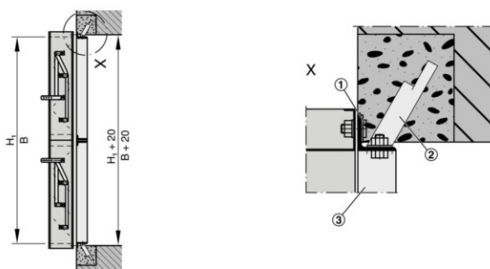

- ① Threaded stud
- ② Fixing tab
- ③ Installation subframe